



Sauer Compressors

for the Navy

- Dependable Compressors:**
- reliable
 - naval know-how
 - world-wide references



www.sauercompressors.de

125 
Sauer
125 Years of Power

Sauer Compressors for the Navy



- **High-Pressure Compressors**
- **Medium-Pressure Compressors**
- **Low-Pressure Compressors**
- **Non-magnetic Compressors**



Sauer Compressors for the Navy are developed on the basis of the philosophy that for the maritime market and especially for the navy market special demands exist. This is the reason that maritime or navy users require different solutions compared to industrial applications.

As a result Sauer Navy compressors were developed especially for use on submarines and naval combat ships. This development was based upon established expertise in the production of navy compressors as well as long experience in the production of commercial compressors.

The main requirements of development are:

- small space requirements,
- light weight,
- reduction of noise and vibration,
- high shock resistance,
- high reliability,
- long maintenance intervals,
- easy service.

Sauer Compressors for the Navy are the answer to these requirements as they incorporate all special features which are vital for naval applications.

Constant innovation, such as the development of the WP 5000 range with 100 % balanced free inertial forces, ensures the technical leadership necessary for future naval applications.



[Upon request Sauer can provide you a full reference list](#)



More than 16 Aircraft Carriers, e.g. the **USS Dwight D. Eisenhower** equipped with 4 x WP 5000



More than 104 Destroyers and Frigates, e. g. the Italian **Francesco Mimbelli** equipped with 2 x WP 4262



Used by more than 50 Navies Worldwide

J.P. Sauer & Sohn Maschinenbau GmbH (formerly Poppe Compressors) have been building special compressors for Navies for over 50 years.

Starting as supplier to the German Navy, Sauer quickly gained a world-wide reputation as a reliable manufacturer of navy compressors. Today more than 50 Navies rely on Sauer compressors.

The reasons for this success are:

- reliability of the compressors,
- knowledge of the special naval demands,
- credibility of the company.

Together with the company Girodin-Sauer, belonging to the Sauer Group since 1989, and its specialist knowledge in the design of swash plate compressors, e.g. in use with the French nuclear submarines, Sauer today is the world market leader for submarine compressors.

Our Range

4-stage water-cooled high-pressure compressors

up to 350 bar



4/5

2- to 4-stage air-cooled high-pressure compressors

up to 350 bar



6/7

Breathing-air compressors air-cooled

up to 420 bar



8/9

Control- and working-air compressors

up to 10 bar



10/11



More than 191 submarines, e. g. the German **U 212** equipped with 1 x WP 5000 and 1 x WP 3232



More than 638 Corvettes and Fast Attack Crafts, e. g. the Brazilian **Inhauma** equipped with 2 x WP 4262



More than 182 Miscellaneous Vessels, e.g. the Royal British Navy **Wave Knight** with 2 x WP 200 and 2 x WP 4330



More than 130 MCMV, e.g. the German **MJ 332** equipped with 2 x WP 3232-600

Sauer HP compressors water-cooled

The Sauer Navy compressors of the series WP 5000 have been specially designed for the use on combat ships destroyers, frigates or submarines. They are available with AC- or DC-motor and can be delivered for surface ships or special highly sophisticated submarine versions. Their special feature is the vertical crankshaft with the 4 cylinders radially arranged around it with the motor direct coupled on top of the compressors.

As an alternative for submarine applications, Sauer offers the unique axial swash type compressor of the TGM design with low space requirement and noise emission.

Technical Data

Water-cooled compressors series – radial/star type					WP 5000/5500					
Type	Stages	Cylinder	Speed rpm	Charging Capacity m ³ /h (FAD)	Power required kW	Weight kg	Length mm	Width mm	Height mm	Frequency Hz
WP 5500 @ 250 bar	4	4	1170	53	14,2	930	970	810	1325	60
			1470	66	21,6					50
			1770	81	26,0					60
WP 5000 @ 250 bar	4	4	1170	105	28,5	1650	1215	1095	1570	50
			1470	133	43,2					60
			1770	162	52,0					50
WP 5500 @ 350 bar	4	4	1170	52	15,3	930	970	810	1325	60
			1470	65	23,3					50
			1770	80	28,0					60
WP 5000 @ 350 bar	4	4	1170	100	30,7	1650	1215	1095	1570	50
			1470	130	46,5					60
			1770	160	56,0					50

Water-cooled compressors series – vertical/in-line type					WP 3230 – 4262					
Type	Stages	Cylinder	Speed rpm	Charging Capacity m ³ /h (FAD)	Power required kW	Weight kg	Length mm	Width mm	Height mm	Frequency Hz
WP 3230-500 @ 230 bar	3	2	970	25	8	650	1400	750	1180	50
			1170	30	10					60
WP 4253/4254 @ 250 bar	4	2	750	80	29	1700	1700	770	1280	50/60
			1200	130	48					50/60
WP 4261/4262 @ 250 bar	4	2	750	80	29	1700	1700	770	1280	50/60
			1200	130	48					50/60
WP 4261/4262 @ 350 bar	4	2	800	80	33	1700	1700	770	1280	50/60
			1200	130	56					50/60

Water-cooled & axial swash plate type compressors series TGM (Girodin-Sauer)										
Type	Stages	Cylinder	Speed rpm	Charging Capacity m ³ /h (FAD)	Power required kW	Weight kg	Length mm	Width mm	Height mm	Frequency Hz
TGM 15/30 @ 250 bar	4	4	1070	15	6,5	360	1000	650	780	50/60
TGM 60/100 @ 250 bar	4	4	620	60	20	1100	1135	940	1300	50/60
			850	80	28					50/60
TGM 150/250 @ 250 bar	4	4	680	150	45	2000	1800	940	1500	50/60

Performance data with 5% tolerance, referred to 20° C and an air pressure of 1013 mbar.
Charging Capacity according to international navy standards.

Series up to 350 bar

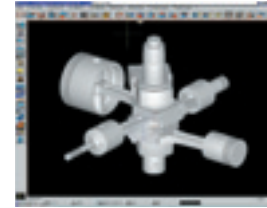

Vertical arrangement of the crankshaft with cylinders radial round it ensures lowest vibration and structure borne noise values.

Material selection for cooling water circuit suitable for most aggressive seawater conditions. Avoidance of dissimilar material combination in all parts of the circuit.

Sophisticated integrated drainage system for lowest drain noise.

Dry cylinder liners and hermetic separation of the water circuits from the oil – and air circuits for highest reliability.

Direct drive by AC or DC motors via an elastic coupling.

Special suction and delivery dampers available for lowest air borne and pipe noise.

If requested the compressor can be equipped with a low maintenance Interstage Membrane Dehydrator (IMD) or traditional dessicant dryer in a module.

High efficient valves for longest maintenance intervals – prearranged in the valves covers for easy and quick maintenance.



Submarine versions designed for cooling water pressure up to 50 bar.

Straight cooler tubes, drawable to both sides of the cooler for easy cleaning and installation. The floating design prevent heat stress in the bundle and consequential damages.



High-efficient separators after each cooler for best air quality. Oil content in the highpressure air of less than 1 ppm.

■ WP 5000 with AC motor and IMD (integrated membran dryers).

Sauer HP compressors air-cooled

In the year 1955 Sauer delivered the first air-cooled light weight HP compressors 3231N, which can still be seen in the German Museum in Munich as first of its kind. Since then Sauer have delivered more than 1000 air-cooled HP compressors for navy applications which due to their special design, work to full satisfaction of the users.

Main features of Sauer air-cooled HP compressors are:

- Light weight
- Robust design
- Low and easy maintenance
- Maximum pressure 350 bar
- To be delivered in non-magnetic version upon request
- Suitable for breathing air supply
- Drive by AC-, DC- or diesel engine
- Available in semi- or non-magnetic design
- Suitable for ambient temperatures up to +60°C

Technical Data

Air-cooled compressors										
Final pressure 40 bar										
Type	Stages	Cylinder	Speed rpm	Charging Capacity m ³ /h	Power required kW	Weight kg	Length mm	Width mm	Height mm	Frequenzy Hz
WP 22 L	2	2	1150	15,9	3,7	120	812	600	630	60
			1450	20,0	4,6					50
			1750	24,0	5,7					60
WP 45 L	2	2	1170	38,0	8,0	310	1210	745	820	60
			1450	48,0	10,0					50
			1750	58,0	12,0					60
WP 65 L	2	2	1170	52,0	10,2	320	1250	745	820	60
			1450	66,0	12,8					50
			1770	80,0	15,4					60
WP 81 L	3	3	1170	63,0	13,7	415	1345	945	900	60
			1470	79,0	15,8					50
			1770	96,0	18,9					60
Final pressure 250 bar										
Type	Stages	Cylinder	Speed rpm	Charging Capacity m ³ /h	Power required kW	Weight kg	Length mm	Width mm	Height mm	Frequenzy Hz
WP 3232	3	3	1170	11,0	5,3	291	920	710	970	60
			1470	14,2	6,8					50
WP 4331	4	4	1470	30,0	14,2	480	1350	720	930	50
			1770	36,0	17,2					60
WP 4341	4	4	1470	54,0	20,5	530	1350	860	860	50
			1770	65,0	24,1					60

Performance data with 5% tolerance, referred to 20° C and an air pressure of 1013 mbar. Charging Capacity according to international navy standards. Performance data on final pressure deviating from above pressures upon request. Maximum pressure 350 bar.

High efficient compressor valves for longest maintenance.
Easy to maintain.

Suitable for ambient temperatures up to 60°C without reduction of performance.

All units can be delivered in semi- or non-magnetic versions upon request.

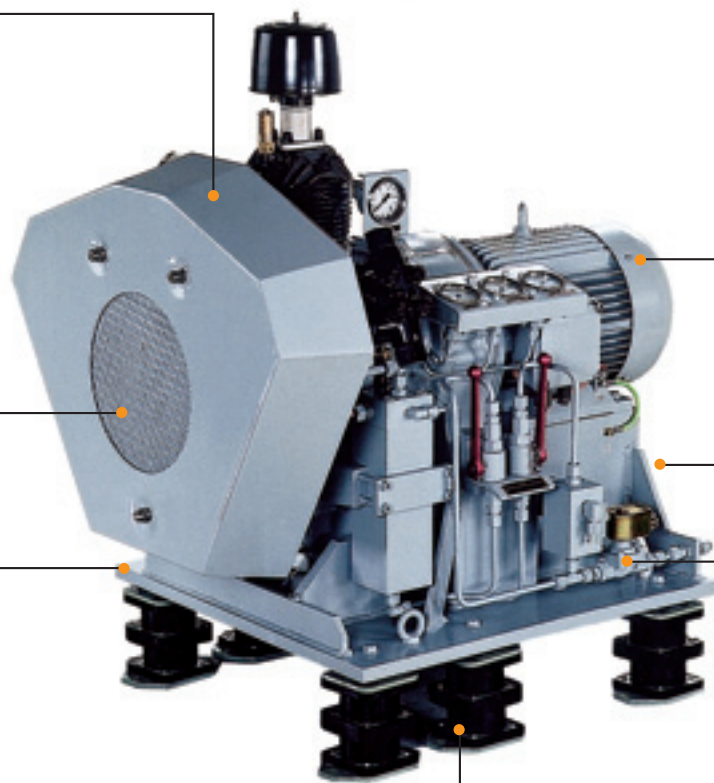

Drive by AC-, DC or diesel engine possible.

Sturdy and robust design. Comparable low weight due to air-cooled design.

Integrated automatic intermediate and final drainage as a standard.

Shock-proof according to all international navy standards.

■ WP 3232 in non-magnetic version for use in MCMV.

Sauer breathing-air compressors

Sauers' quality and leading position in the market for Navy compressors are well known. With the introduction of the unique HP compressor block 'Tornado' this quality and performance is now also available for breathing air compressors. Sauers' Navy breathing air compressors can be delivered according to several shock and vibration standards from simple LROs rules to highest Navy standards like US Mil Std 901 or German BV0432 and 044.

The heart of each breathing air station is the very robust compressor block – a block which is designed to withstand highest demands as they occur for naval applications such as inclination, shock, vibration and last but not least high temperatures and continuous operation.

The vertical arrangement of the running gear of the 'Tornado' models WP 3215 and WP 4325 has been adopted from the water-cooled WP 5000 compressors which are used in submarines, frigates and aircraft carriers. It ensures lowest noise emission and structureborne noise.

The Sauer breathing air compressor for Navy has everything required for a complete installation: fully automatic electronic control, noise insulation down to 72 db(A), integrated filter, demistor and condensate collecting tank. Filtration can be delivered according to all international standards such as DIN EN 12021, BS 4275 and BS 4001 or US CGA Grade D+E and Navy standard FS Grade A+B.

High performance axial-flow fan integrated with coolers in a flow optimized housing for lowest recooling temperatures and best air quality.



Technical Data

Dimensional datas and weight for *Comsilent Version*

Tornado										
Final pressure 420 bar										
Type	Stages	Cylinder	Speed rpm	Charging Capacity liter/min	Power required kW	Weight kg	Length mm	Width mm	Height mm	Frequenzy Hz
WP 3215 Tornado	3	3	1170	275	5,4	525	1580	775	1525	60
			1470	340	6,7					50
			1770	390	8,4					60
WP 4325 Tornado	4	4	1170	390	8,4	595	1580	775	1525	50
			1470	500	10,0					60
			1770	570	12,0					50
WP 4331	4	4	1470	625	14,0	650	1600	900	1500	50
			1770	600	17,0					60

Performance data with 5 % tolerance, referred to 29°C and an air pressure of 1013 mbar.
Capacity measured at charging rate up to a final pressure of 300 bar.

Tornado

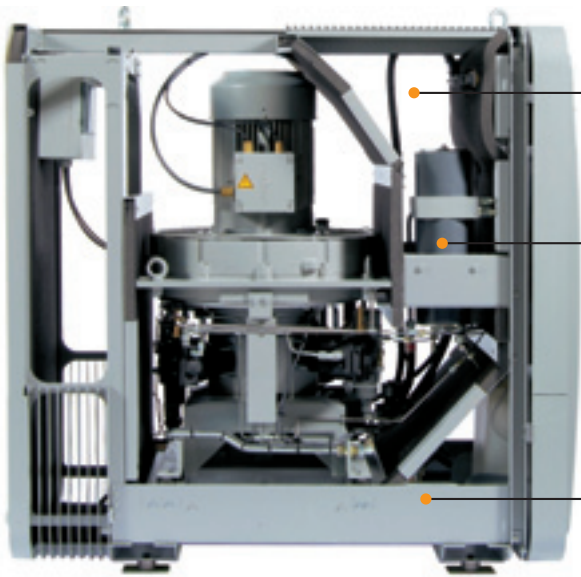

Front door: Easy access to control unit, condensate collecting tank and filter accessories.

Optimized cooling air flow: Compressed air treatment and filtration in cold air stream.

Integrated demistor vessel.

Side covers easy to remove for inspection and maintenance.



Integrated condensate demistor and -collecting tank (20 litres).

Breathing air filtration suitable for all international standards.



Fully automatic electrical control and supervision.

Complete Sauer breathing air compressor Tornado WP 4325 with filling panel and hoses for bulkhead mounting.

Sauer can deliver all required breathing air accessories. These can be delivered separately or already integrated in the breathing air station.



Control- and working-air

For control and working air applications Sauer can delivered special screw- and piston compressors in naval design. Sauer low pressure air compressors can be delivered according to several shock and vibration standards from simple LROs rules to highest Navy standards like US Mil Std 901 or German BV0432 and 044.

Cooling is available for both screw- and piston compressors by seawater, fresh- or chilled water as well as by air. If required special air treatment can be included in the scope of supply either to be delivered separately or attached to the compressor in a module.

As an alternative to the screw compressors of the SC range Sauer offers direct driven and frequency controlled screw compressors of the SD range. This alternative offers lower maintenance and higher reliability due to missing V-belts. It also allows smaller air receivers due to soft capacity adaption as per the actual demand.

The highly reliable Sauer piston compressors offer same advantages and technology as the well-known 30 bar starting-air compressors.

Technical Data

Screw type compressor V-belt driven				Technical Data for a final pressure of 8 bar				Dimensions			
Type	Version	Final pressure max. bar	Motor speed rpm	Charging* Capacity m ³ /h	Power consumption kW	Heat Dissipation kJ/sec	Weight kg	Length mm	Width mm	Height mm	
SC 26	50 Hz	10	2930	148	16,0	17,6	450	1270	795	1070	
	60 Hz		3530	177	19,2	21,1					
SC 42	50 Hz	10	2960	234	28,6	31,5	580	1270	795	1170	
	60 Hz		3550	280	34,3	37,8					
SC 52	50 Hz	10	2980	278	33,4	36,7	595	1270	795	1170	
	60 Hz		3555	334	40,0	44,0					
Screw type compressor direct driven				Technical Data for a final pressure of 8 bar				Dimensions			
Type	Version	Final pressure max. bar	Motor speed rpm	Charging* Capacity m ³ /h	Power consumption kW	Heat Dissipation kJ/sec	Weight kg	Length mm	Width mm	Height mm	
SD 22	50/60 Hz	10	frequency controlled	200	21,0	23,0	310	1050	795	1240	
SD 30	50/60 Hz	10	frequency controlled	245	28,5	31,0	370	1050	795	1240	
SD 38	50/60 Hz	10	frequency controlled	325	36,0	40,0	560	1550	810	1170	
Piston compressor				Technical Data for a final pressure of 8 bar				Dimensions			
Type	Final pressure max. bar	Stages	Cylinder	Speed rpm	Charging Capacity m ³ /h	Power consumption kW	Heat Dissipation kJ/sec	Weight kg	Length mm	Width mm	Height mm
WP 146 L air-cooled	10	2	2	1170	116	17	19	850	1420	870	880
				1470	150	21	23	850			
				1770	175	25	28	850			
WP 226 L air-cooled	10	2	2	1170	220	30	33	880	1735	1030	1020
				1470	280	36	40	880			
				1770	330	42	46	880			
WP 200 water-cooled	15	2	2	1170	144	23	30**	770	1500	1000	890
				1470	177	28	37**	800			
				1770	214	34	45**	800			

Performance data with 5% tolerance, referred to 20° C and an air pressure of 1013 mbar.

Capacity of screw-type compressors according to DIN-ISO 1945.

Weights and dimensions for standard units with three-phase A. C. motor, IP 54, and flexible mounting. Water-cooled screw-type compressors upon request.

* Larger capacity up to 2000 m³/h or capacity for other final pressures upon request.

** Cooling water demand for delta $\Delta t = 10^\circ \text{C}$



- LP Compressor station SC 26 with integrated desiccant dryer. Shockproof, sea-water cooled version.

Your local agent:

J.P. Sauer & Sohn
Maschinenbau GmbH

P.O. Box 9213
D-24157 Kiel
Phone +49 (0) 4 31/39 40-0
Fax +49 (0) 4 31/39 40-24
e-mail: info@sauersohn.de
Internet: www.sauersohn.de



Subject to technical change without notice.
Please refer to www.sauersohn.de for latest version of the brochure.